

Quick-Flex Standard Spacer Coupling Installation Guide

Please complete the following steps to install QM Quick-Flex standard spacer couplings.

You should have the following pieces before starting the job:

- 1 Coupling hub
- 1 Flanged hub
- 1 Spacer body
- 1 Insert
- 1 Cover* with included hardware

**Please note: It is critical to identify what style cover you are using, as this will change the hardware included as well as the installation procedure.*

There are three types of covers (Figure 1):

- Standard cover: QF5 through QF175 use a standard snap ring to secure cover in place. QF250 and larger use eight bolts with lock washers.
- Horizontal split cover: This cover is free floating, and all sizes come with four bolts for securing the two halves together around insert.
- Vertical split cover: QF15 through QF250 use eight bolts around the rim to secure the two halves together, QF500 through QF1890 use 16 bolts and QF3150 and larger use 20 bolts. QF15 through QF175 use standard snap rings to hold cover tight axially on the coupling hub. QF250 and larger use eight bolts with lock washers.

Figure 1. Quick-Flex cover types and included hardware

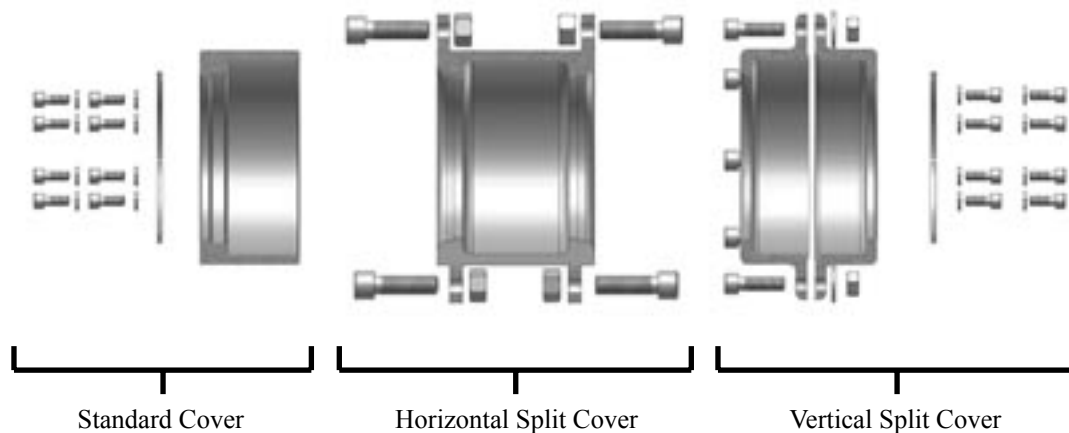

Installation:

Please note: The Quick-Flex standard spacer coupling must be oriented with the flanged hub on the drive shaft and the coupling hub with insert on the driven shaft (Figure 2),

1. Check the bore size of the coupling hub and flanged hub to the shafts and ensure that they are the correct bore size to fit the application.
2. If necessary, clean and deburr the shafts.
3. Identify cover style:
 - a. If using a standard cover, it should be placed on the driven shaft. If cover uses a snap ring, slide the snap ring down the shaft, then slide the cover onto shaft with the larger opening facing the shaft separation.
 - b. If using a horizontal split cover, leave cover aside and continue to Step 4.
 - c. If using a vertical split cover, QF15 through QF175 use snap rings to secure in place, QF250 and larger use bolts and washers. If cover uses a snap ring, slide the snap ring down the driven shaft and leave the four pieces of the cover aside.
4. Install the coupling hub. It should be mounted so that the end of the shaft is flush with surface “A” as shown in Figure 2. It is acceptable for the shaft to extend past “A” as long as it is not past the teeth shown as “B”.
Please note: Standard hubs are supplied with a clearance fit and should slide onto the shaft without excessive force. If the hubs have been ordered with interference fit then heat the coupling halves to approximately 572 F (300 C) before installing on shafts.
5. Install the flanged hub using the spacer body and insert to locate the flanged hub on the drive shaft. This will set the hubs at the minimum hub gap (G_{Min}) dimension when the insert is tight between the coupling hub and spacer body, ensuring proper clearance. For specific G_{Min} and G_{Max} dimensions see Table 1.
6. Tighten the flanged hub and coupling hub securely to the shafts using the set screws.
7. Check coupling for misalignment (Table 2) and align as necessary.
8. Install the cover:
 - a. Standard cover: slide the cover over the coupling hub and insert until fully rested against the shoulder of the coupling hub. QF5 through QF175 use standard snap rings to hold the cover in place. QF250 and larger couplings use eight bolts and washers. Use the included hardware to secure the cover.
 - b. Horizontal split cover: place each half over the insert and secure using the four bolt/washer/nut hardware combinations supplied.
 - c. Vertical split cover: match the four pieces into two complete cover halves using the flange face detail to distinguish the two halves. For QF250 and larger, make sure the cover half with the eight holes for mounting to the coupling hub is on the coupling hub side, not the spacer side. Bolt the four pieces together using the supplied hardware ensuring the splits in each half are rotated 90 degrees relative to each other. Install the snap ring or bolts to secure the cover to the coupling hub.
9. Ensure the four spacer body bolts through the flange are tight along with all other bolts and set screws.

RPM and Balance

The QM Quick-Flex coupling is machined on all surfaces and thus its dynamic balance is good. If the coupling is run at a high speed it is important that the key used to attach the coupling hubs is the same length as the coupling hub. The set screws should also be changed to full length to fill the hole.

Figure 2. Proper shaft-to-hub alignment

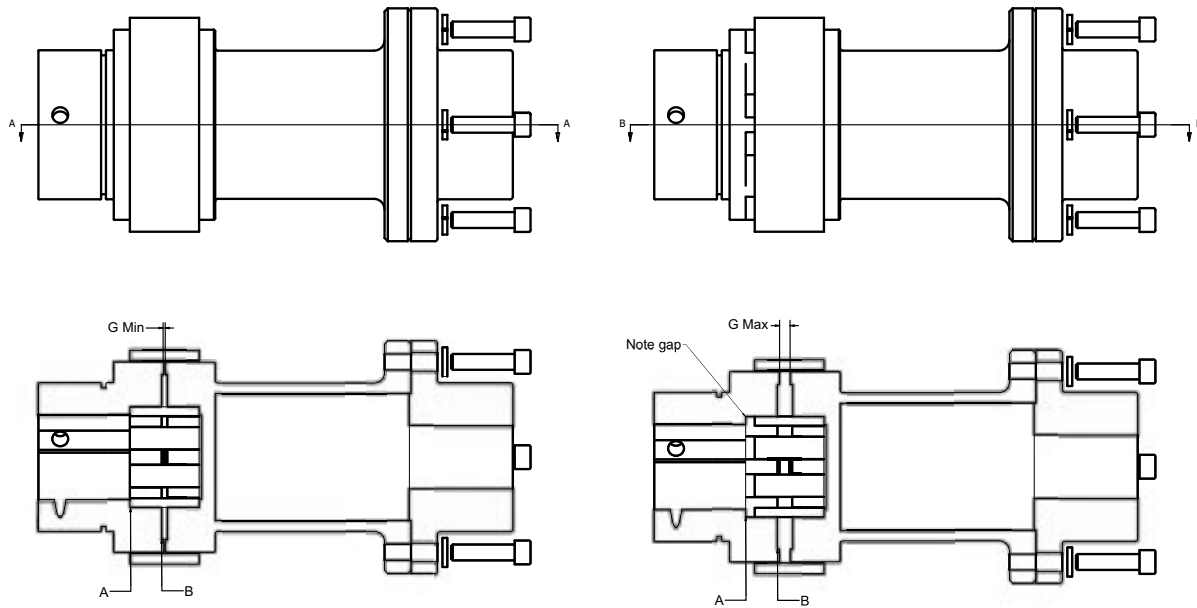

TABLE 1. Quick-Flex Coupling Hub Gap (G) Dimensions

Coupling Size	Standard Cover		Horizontal Split Cover		Vertical Split Cover	
	G _{Min} (in.)	G _{Max} (in.)	G _{Min} (in.)	G _{Max} (in.)	G _{Min} (in.)	G _{Max} (in.)
QF5	0.063	0.092	n/a	n/a	n/a	n/a
QF15	0.036	0.110	0.036	0.099	0.036	0.126
QF25	0.080	0.205	0.080	0.133	0.080	0.140
QF50	0.035	0.208	0.035	0.101	0.035	0.220
QF100	0.140	0.290	0.140	0.380	0.140	0.380
QF175	0.188	0.208	0.188	0.375	0.188	0.348
QF250	0.100	0.230	0.100	0.365	0.100	0.250
QF500	0.125	0.250	n/a	n/a	0.125	0.375
QF1000	0.160	0.388	n/a	n/a	0.160	0.410
QF1890	0.202	0.278	n/a	n/a	0.202	0.454
QF3150	0.070	0.305	n/a	n/a	0.070	0.455
QF10260	0.127	0.505	n/a	n/a	0.127	0.492

TABLE 2. Quick-Flex Misalignment Tolerances

Coupling Size	Radial Misalignment Tolerance (in.)	Axial Misalignment Tolerance (in.)	Angular Misalignment Tolerance (degrees)
QF5	0.02	0.07	2°
QF15	0.03	0.11	2°
QF25	0.03	0.11	2°
QF50	0.03	0.11	2°
QF100	0.05	0.15	2°
QF175	0.05	0.17	1.3°
QF250	0.05	0.23	1.3°
QF500	0.05	0.23	1°
QF1000	0.05	0.23	1°
QF1890	0.05	0.31	1°
QF3150	0.07	0.31	1°
QF10260	0.07	0.31	1°

North American Locations: Western Canada – Prince George, BC Eastern Canada – Mississauga, ON Western US – Ferndale, WA Southern US – Irving, TX Eastern US – Litchfield, OH

QM Bearings designs, manufactures and markets rugged Blue Brute bearings, Quick-Flex couplings, rigid compression couplings and conveyor sprockets. The company's precise manufacturing methods and innovative solutions have won over thousands

661-5568 or (360) 384-6673.